

ENGINEERING DRAWING

DEC 2018

OUR CENTERS :

KALYAN | DOMBIVLI | THANE | NERUL | DADAR

Contact - 9136008228

Q.1. (a) A stick is 130 mm long in initially tangent to semicircle of 80 mm diameter at its left side corner. This stick now rolls over the circumference of semi circle without slipping. Draw the locus of the end point of the stick, which is away from the semicircle and name the curve. (6)

SOL:

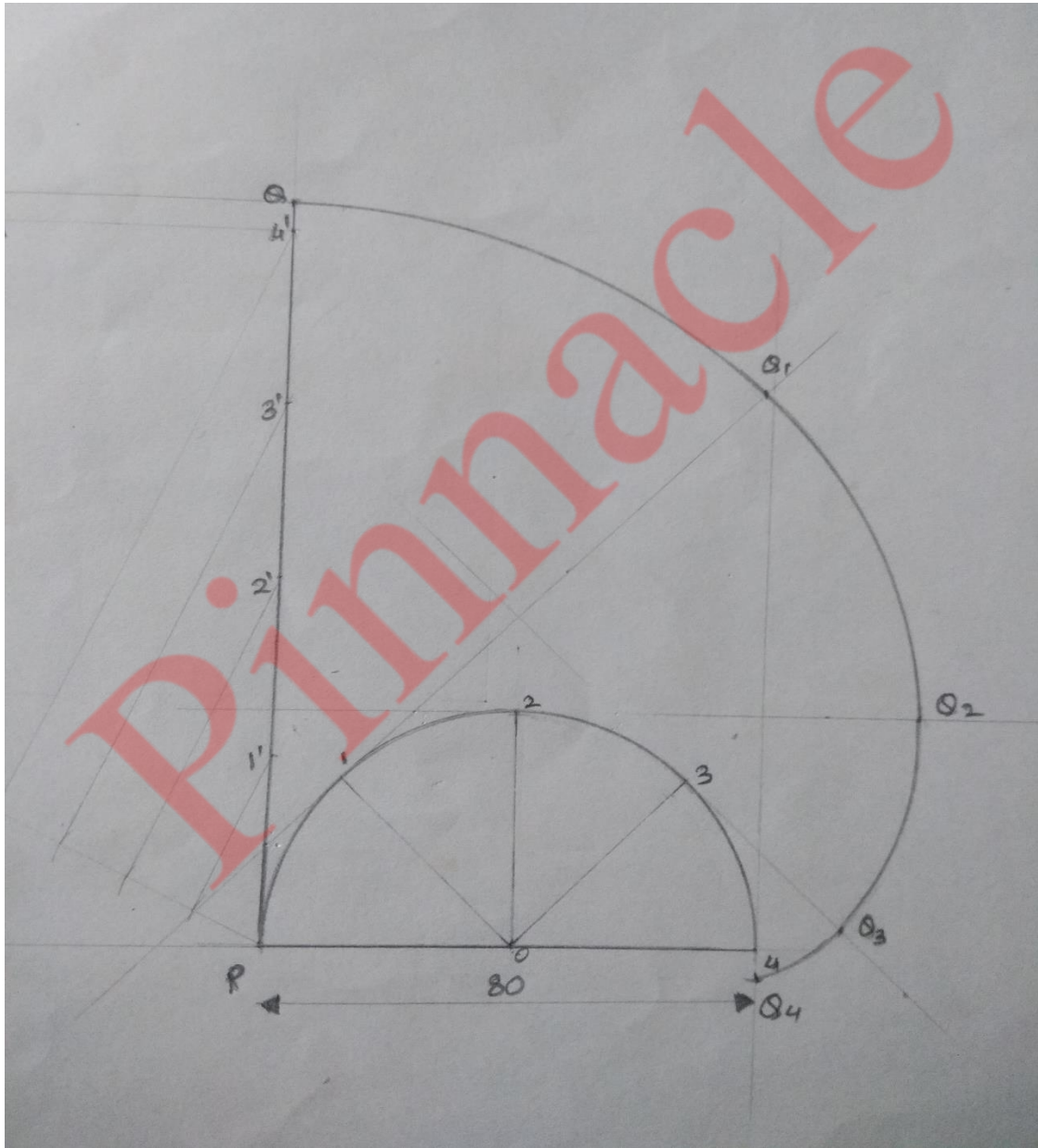

OUR CENTERS :

KALYAN | DOMBIVLI | THANE | NERUL | DADAR

Contact - 9136008228

Q.1. (b) For the object shown in the figure draw the following views –

(i) Front view in the direction of arrow.

(5)

(ii) Top view.

(6)

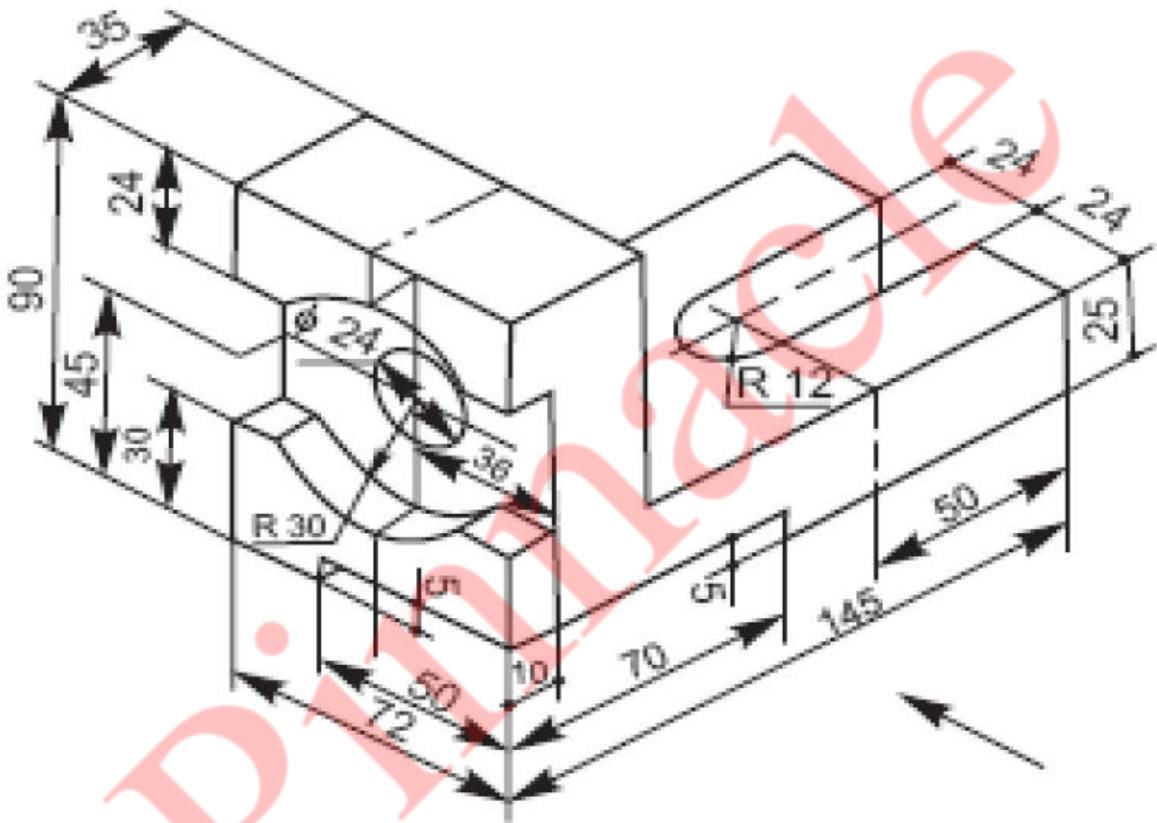

OUR CENTERS :

KALYAN | DOMBIVLI | THANE | NERUL | DADAR

Contact - 9136008228

SOL:

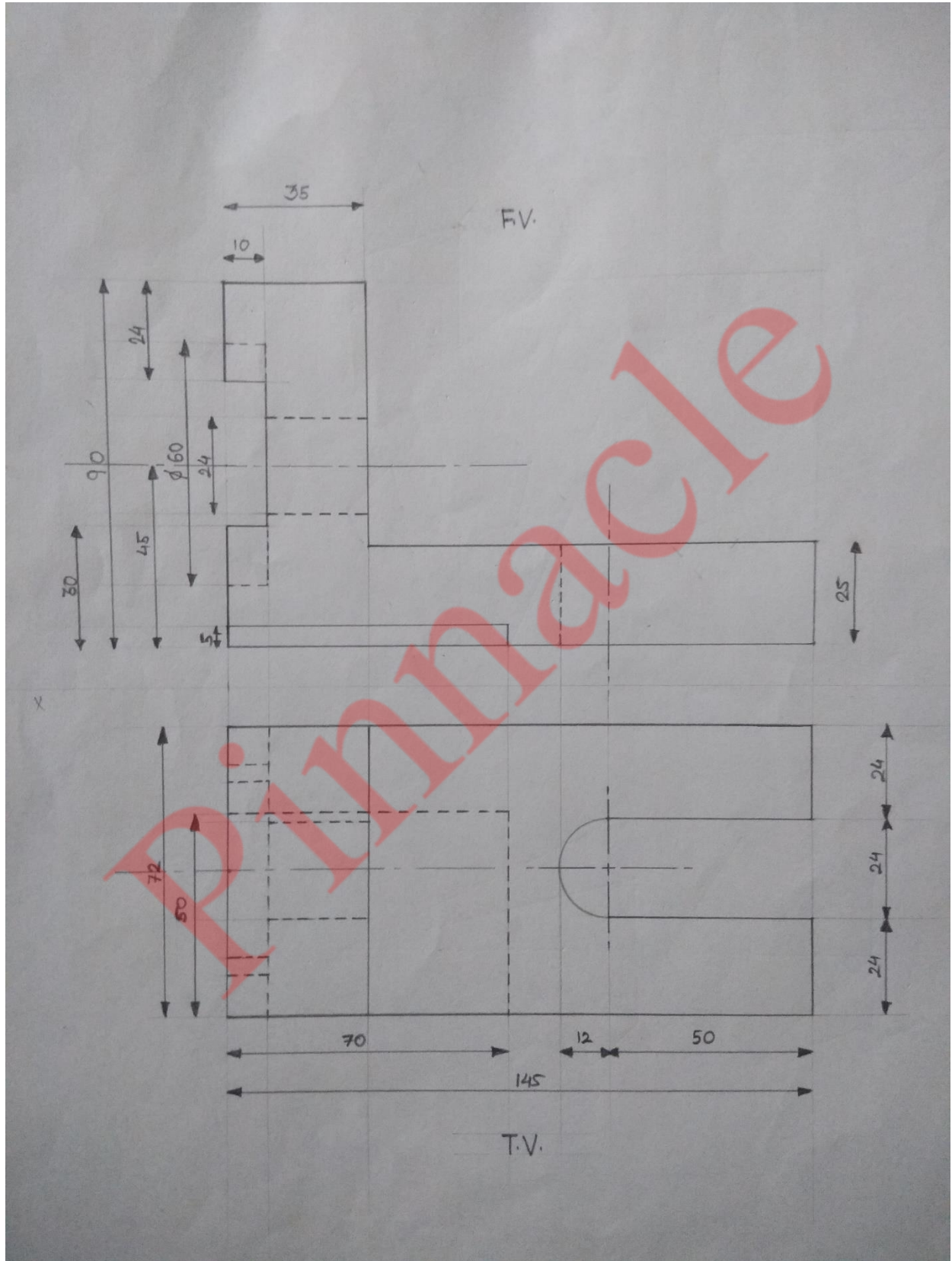

- Q.2. For the object shown in figure draw the following views –
- i. Sectional front view from X-direction section along A-A. (4)
 - ii. Side view from Right. (4)
 - iii. Top view. (5)
 - iv. Insert the major dimensions. (2)

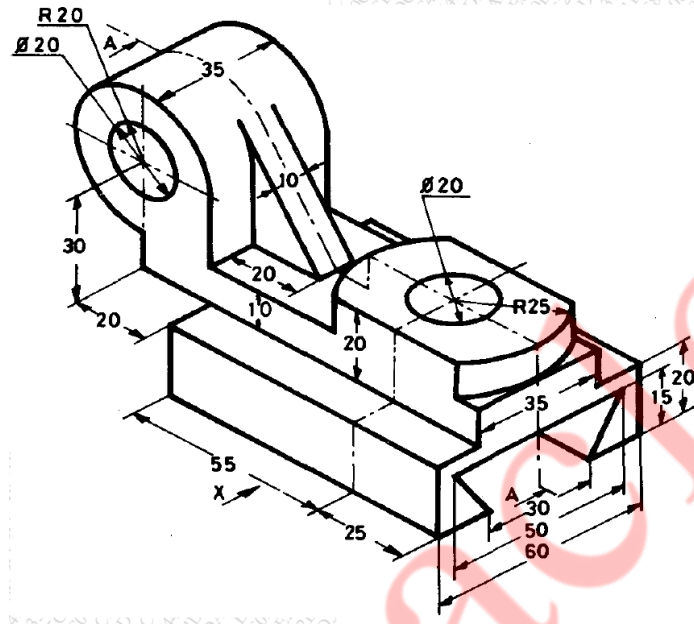

SOL:

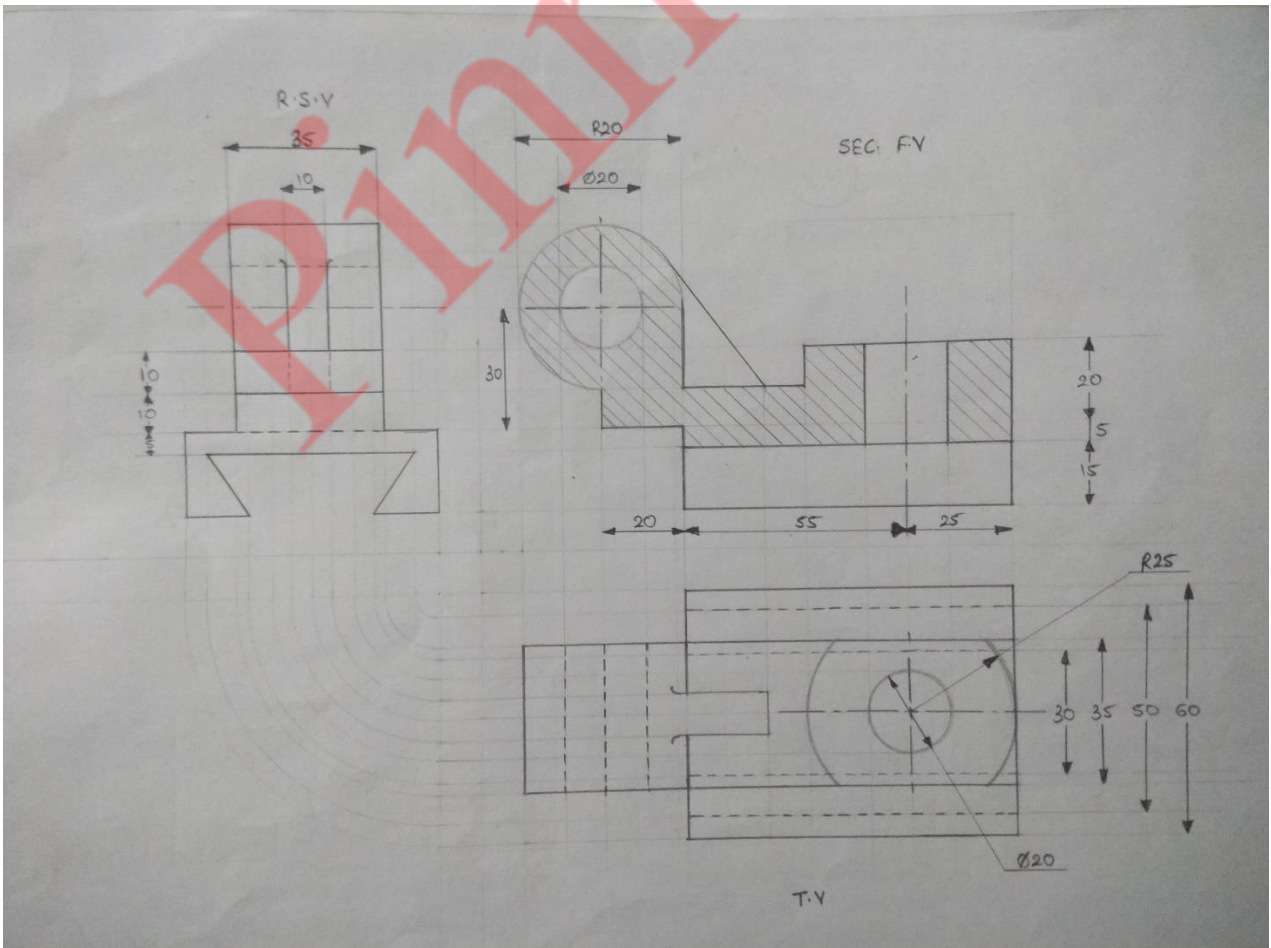

Q.3. A pentagonal pyramid, side of base 35 mm and axis 70 mm long, is lying on one of its corner on the HP such that the triangular surface opposite to the corner is parallel to HP and perpendicular to VP, and base edge containing that triangular surface is parallel to both the HP and VP. Draw the projections of the solid when the apex is of the pyramid is nearer to the observer. (15)

SOL:

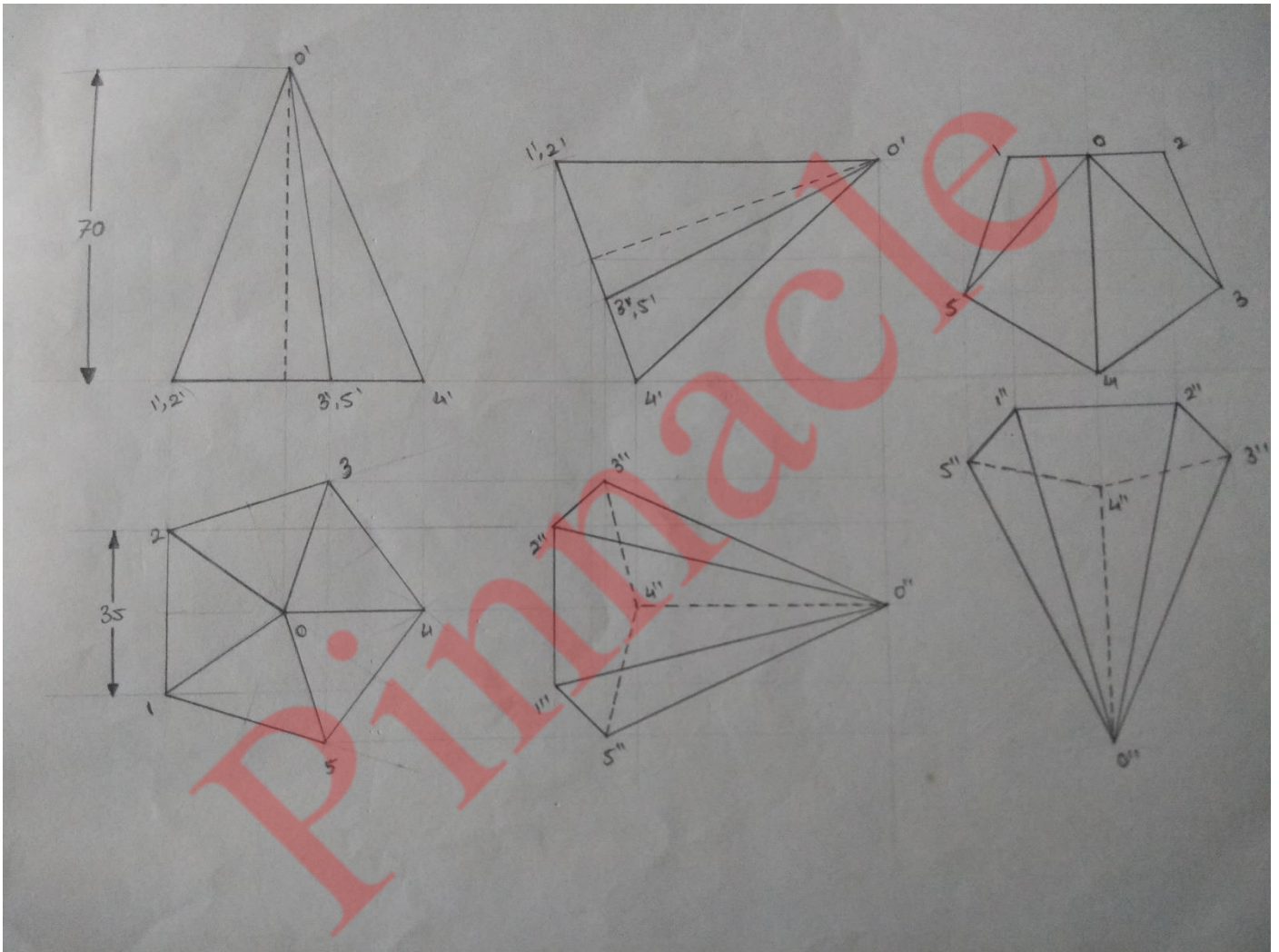

Q.4. (a) A cylinder of 50 mm diameter of base and length of an axis has resting on one point of the circumference in VP. Draw its projections if one of the generators is inclined at 30° to VP and parallel to HP. (6)

SOL:

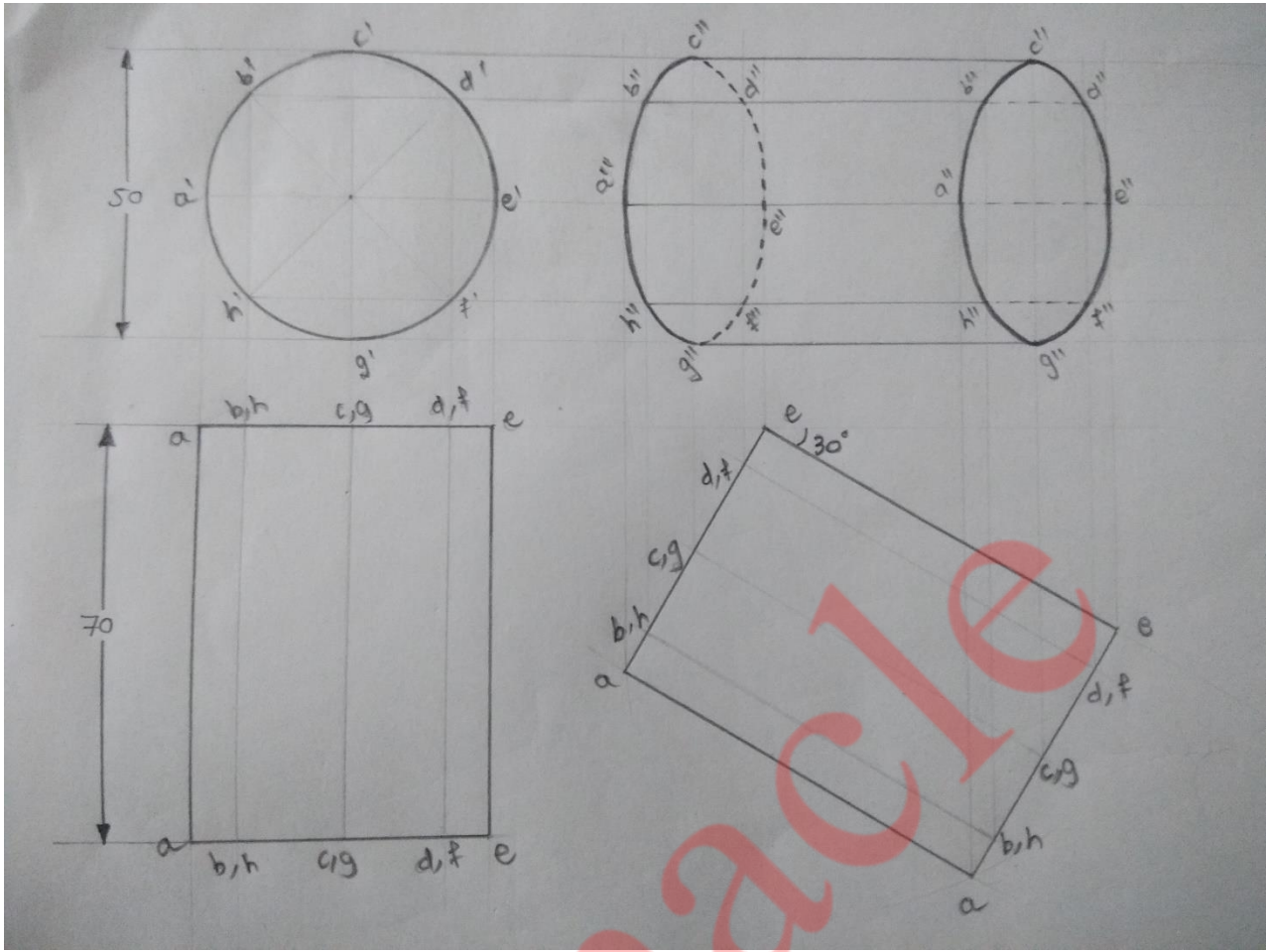

Q.4. (b) Figure Shows three views of an object. Draw its isometric view with 'O' as origin.

(9)

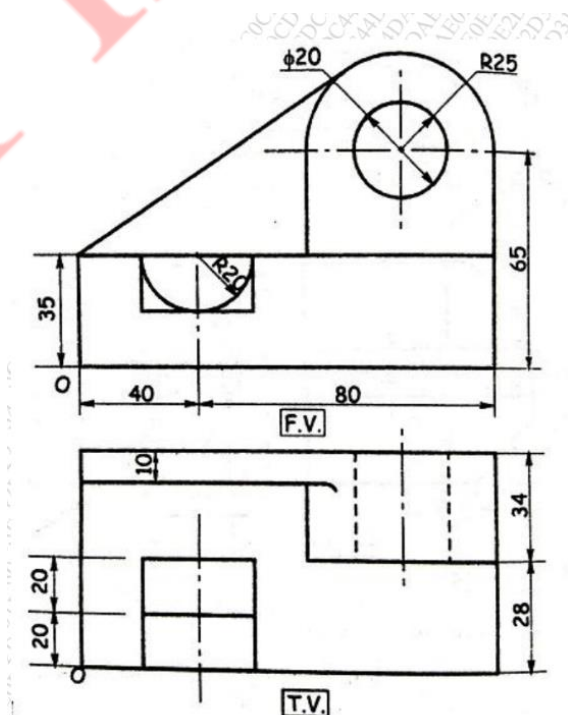

OUR CENTERS :

KALYAN | DOMBIVLI | THANE | NERUL | DADAR

Contact - 9136008228

SOL:

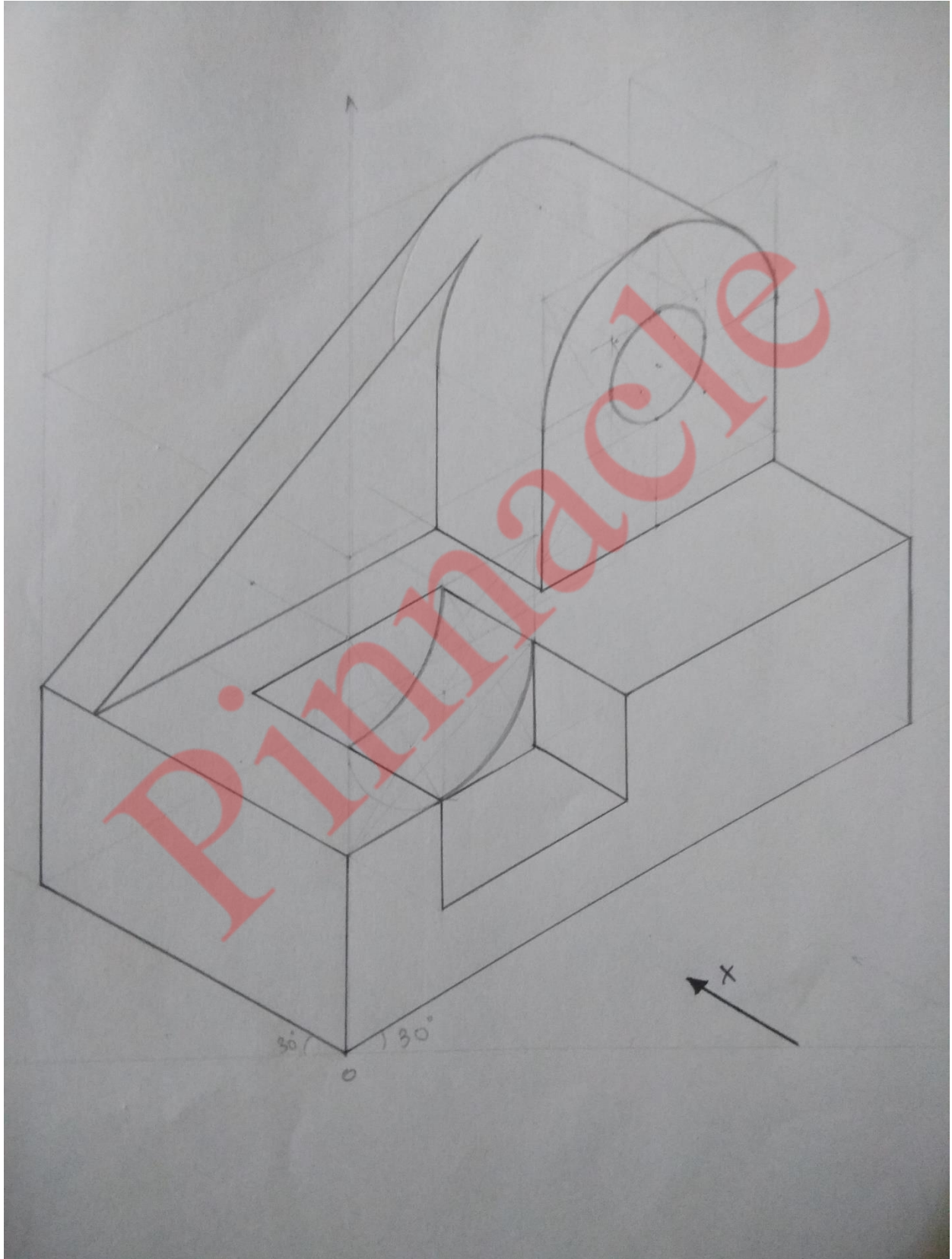

OUR CENTERS :

KALYAN | DOMBIVLI | THANE | NERUL | DADAR

Contact - 9136008228

Q.5. A pentagonal pyramid side of base 40 mm and height 80 mm is resting on HP on its base with one of the edge of base parallel to VP and away from VP. It is cut by an AIP bisecting the axis, the distance of the section plane from apex being 13 mm, if the apex portion is removed, draw the elevation and sectional plane of the pyramid and show the true shape of the section. Also draw the development of the lateral surface of the remaining part of the pyramid. (15)

SOL:

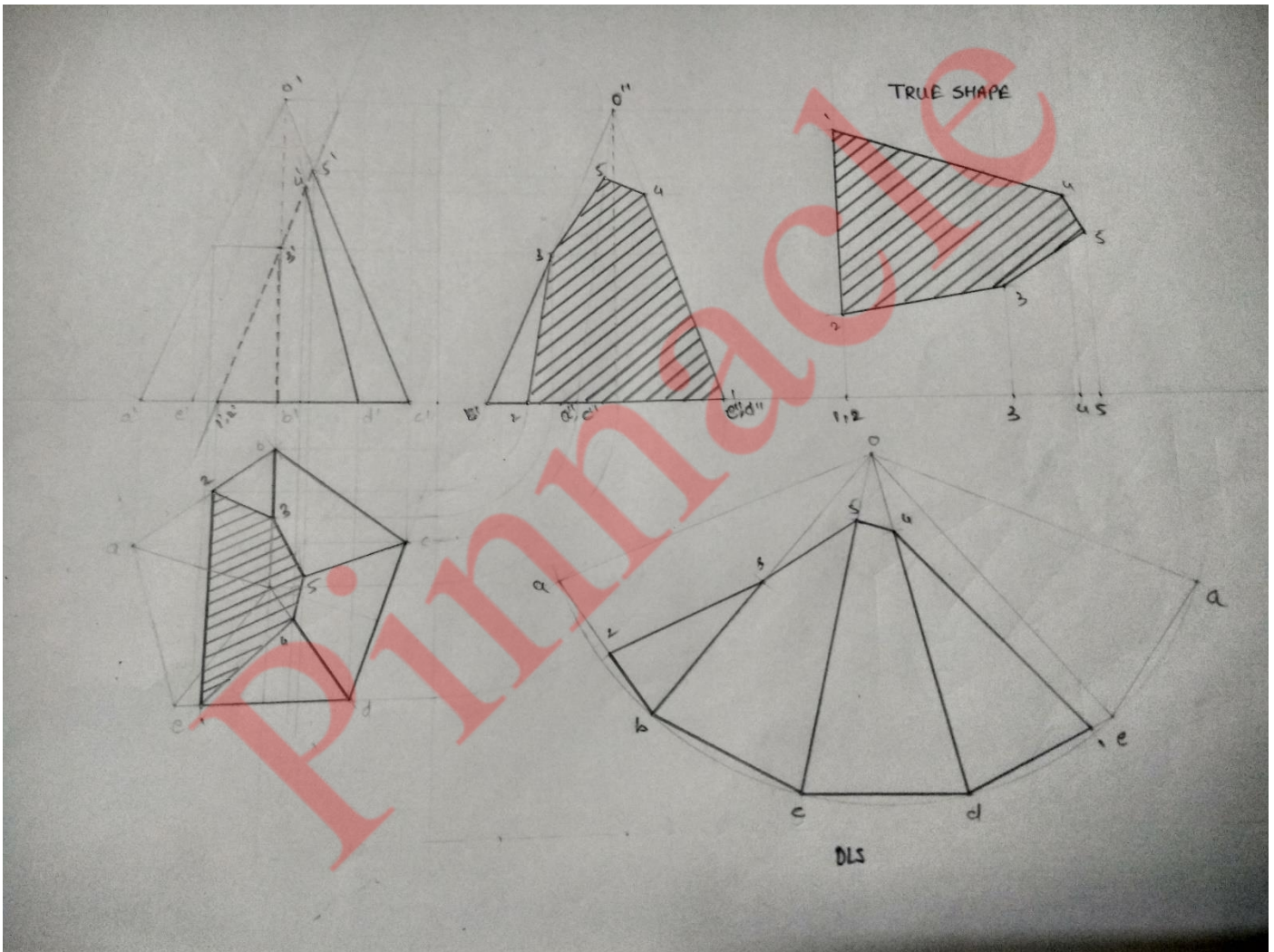

Q.6. (a) The F.V. of 85 mm long straight line AB measures 60 mm while its T.V. measures 70 mm. Draw the projection of AB if its end A is 10 mm above HP and 20 mm behind VP. While its end B is in first quadrant. Draw the projections of line and determine the inclination of line AB with the reference planes. (9)

OUR CENTERS :

KALYAN | DOMBIVLI | THANE | NERUL | DADAR

Contact - 9136008228

SOL:

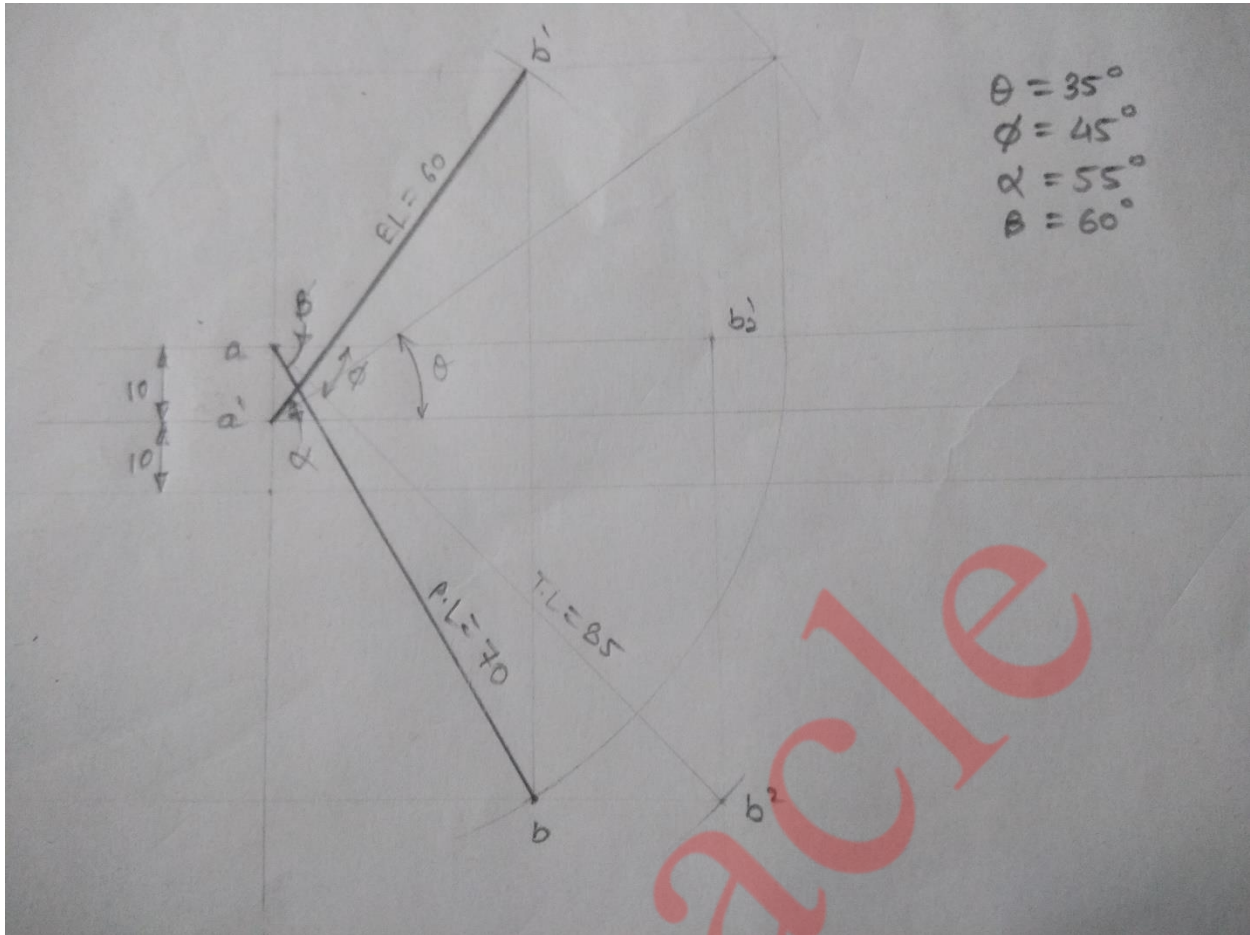

Q.6. (b) Figure shows two views of an object. Draw its isometric view with 'O' as origin

(6)

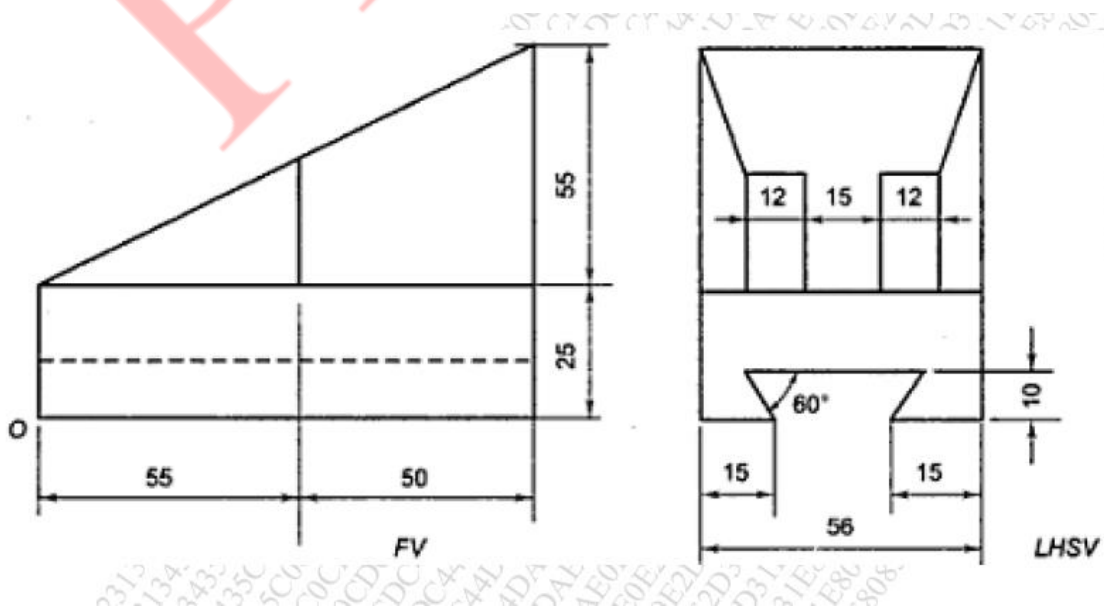

OUR CENTERS :

KALYAN | DOMBIVLI | THANE | NERUL | DADAR

Contact - 9136008228

SOL:

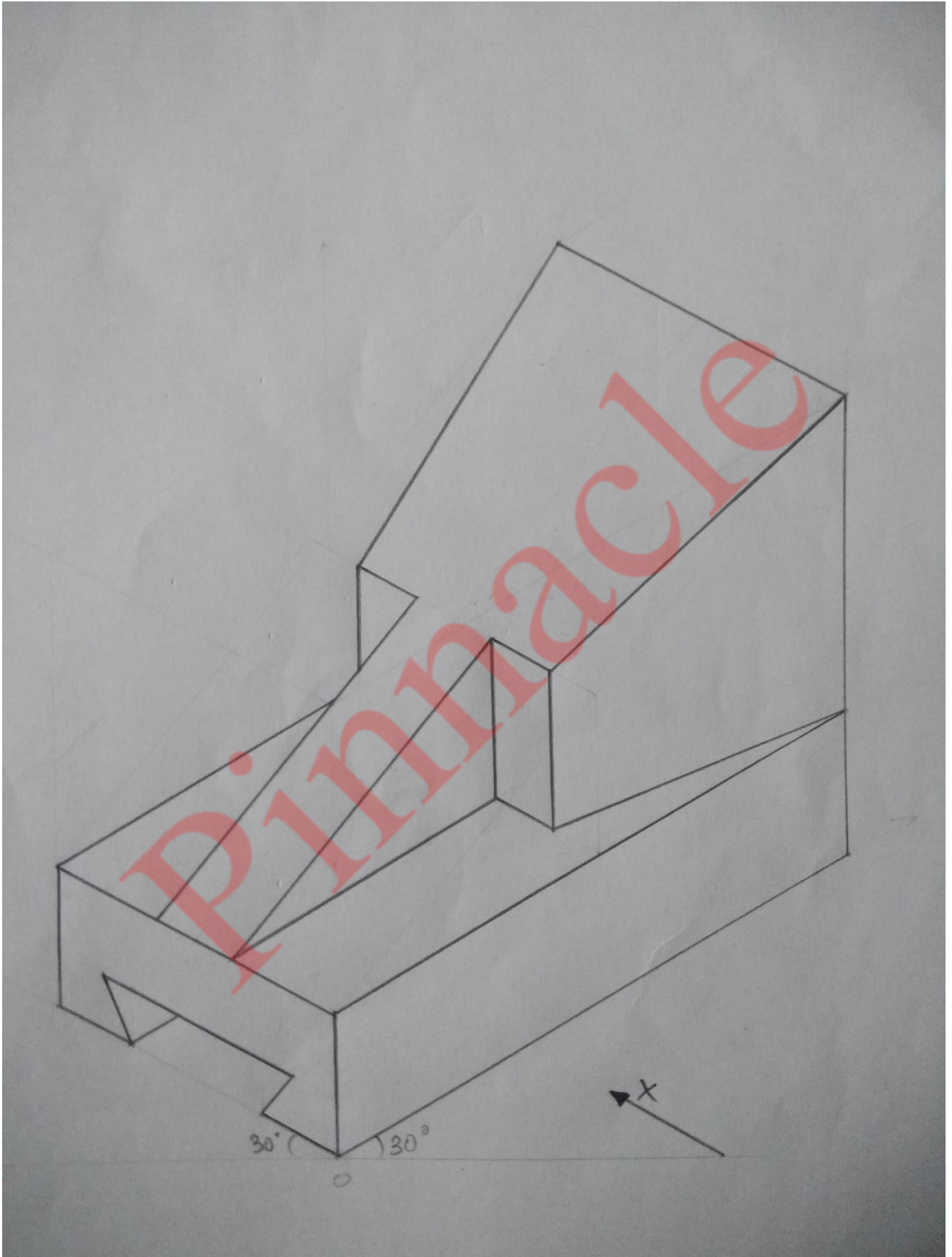

OUR CENTERS :

KALYAN | DOMBIVLI | THANE | NERUL | DADAR

Contact - 9136008228

Pinnacle

OUR CENTERS :

KALYAN | DOMBIVLI | THANE | NERUL | DADAR

Contact - 9136008228